



Royal Industrial Suppliers

Quality Fasteners Specialist

No. 4, M.G.S. Complex, Benki Nawab Street, S.P. Road Cross, Bangalore 560002

An ISO 9001:2015 Certified Co



8310165941 / 9008782885



sales@royalfastenersindia.com



www.royalfastenersindia.com

PLASTITE SCREW CSK PHILIPS

≈WN 1413

CATALOGUE NUMBER: R4A74

AISS 304 A2

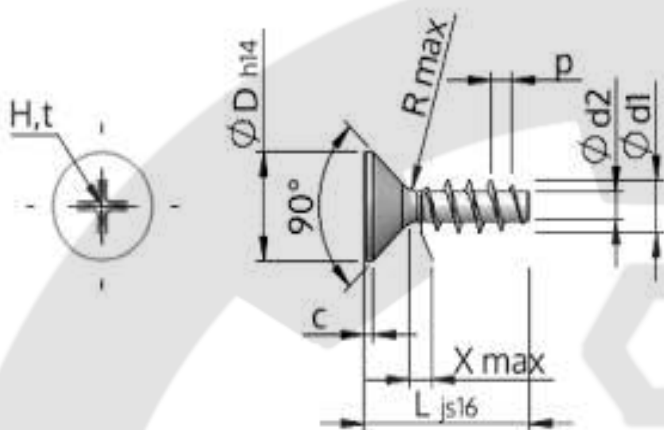

Parameter ↓	Size→	K16	K18	K20	K25	K30	K35	K40
Ext Dia	d1	1.60	1.80	2.00	2.50	3.00	3.50	4.00
Core Dia	d2	0.92	1.04	1.15	1.40	1.66	1.91	2.17
Pitch P ±10%		0.67	0.80	0.89	1.12	1.34	1.57	1.79
Thread Runout X max	L>3*d1	1.60	1.80	2.00	2.50	3.00	3.50	4.00
	L≤3*d1	0.80	0.90	1.00	1.30	1.50	1.80	2.00
Head Dia	D	2.60	2.60	3.50	4.70	5.50	7.30	8.40
Head Height	K	1.10	1.20	1.40	0.55	0.55	0.65	0.70
Slot Width	E	1.60	1.80	2.30	2.60	2.70	3.90	4.20
Drive Size	H	PH0	PH0	PH1	PH1	PH1	PH2	PH2
Slot Depth	t Max	0.85	1.00	1.25	1.43	1.56	1.96	2.22

Send your Orders / Enquiries along with the following Item Codes

All Dimensions are in MM

Len	Dia	1.60	1.80	2.00	2.50	3.0	3.5	4.0
4	R4A7410604	R4A7410804	R4A7402004	R4A7420504				
5	R4A7410605	R4A7410805	R4A7402005	R4A7420505	R4A7403005			
6	R4A7410606	R4A7410806	R4A7402006	R4A7420506	R4A7403006	R4A7430506		
8	R4A7410608	R4A7410808	R4A7402008	R4A7420508	R4A7403008	R4A7430508	R4A7404008	
10	R4A7410610	R4A7410810	R4A7402010	R4A7420510	R4A7403010	R4A7430510	R4A7404010	
12	R4A7410612	R4A7410812	R4A7402012	R4A7420512	R4A7403012	R4A7430512	R4A7404012	
14	R4A7410614	R4A7410814	R4A7402014	R4A7420514	R4A7403014	R4A7430514	R4A7404014	
16	R4A7410616	R4A7410816	R4A7402016	R4A7420516	R4A7403016	R4A7430516	R4A7404016	
20			R4A7402020	R4A7420520	R4A7403020	R4A7430520	R4A7404020	
25					R4A7403025	R4A7430525	R4A7404025	
30					R4A7403030	R4A7430530	R4A7404030	

Sizes in BLUE are non-preferred. Availability is limited and MOQ is higher.

Data is strictly informative.

Note: All Austenitic Stainless Steel Fasteners may exhibit some Magnetic Properties due to the Manufacturing Process.

Refer: ISO 3506-2 Annex F